



54, Annapurna Industrial Estate, Tilak Road,
Ghatkopar (E), Mumbai - 400 077 India
Tel: +91-22-21029911
E-mail: sales@excellaelectronics.com



BLOWER

E-270

Item	Specification
Size	419 X 143 X 131mm
Motor	Capacitor Induction
Bearing	Ball
Impeller	Reinforced Plastic
Frame	Steel
Weight	2.6Kg
Operation Temp	-20°C ~60°C
Life	30000H

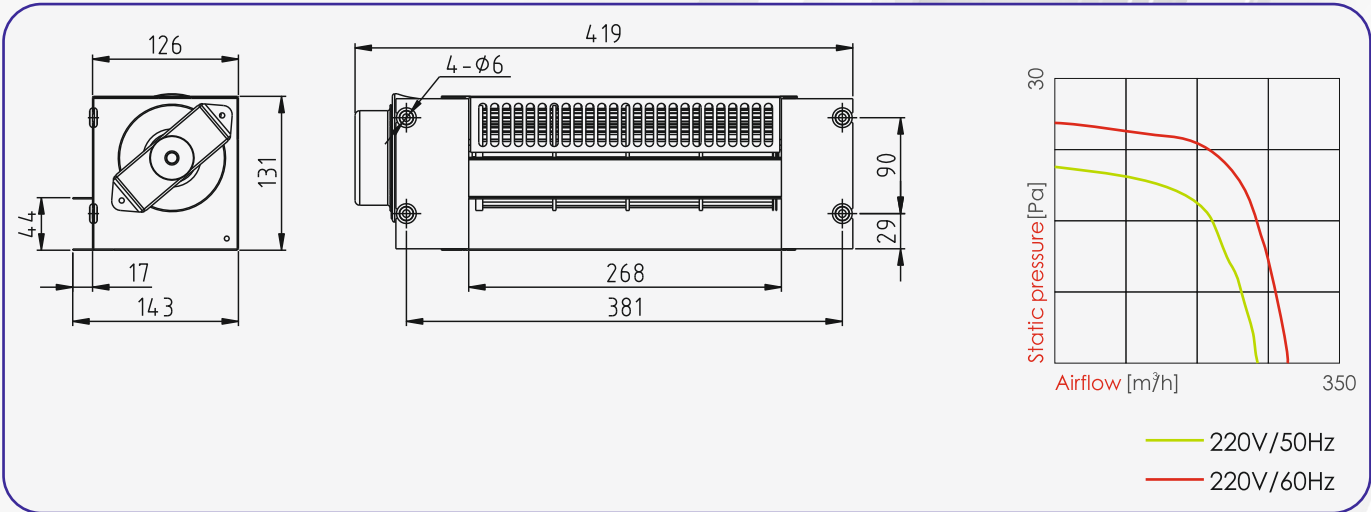

TECHNICAL DETAILS:

MODEL	ZFB - 9B
Voltage VAC	230
Freq. (Hz)	50/60
Current (A)	0.09/0.11
Power (W)	21/25
Speed (RPM)	1300/1400
AIRFLOW (M³/H)	270/290
NOISE (dB)	47